



# canflex (USA), Inc.

"Heavy Duty Boom for Open Water / Terminals"

## "MODEL OCB-1500X"



<b>MODEL</b>	<b>OCB-1500X</b>
<b>Freeboard</b>	0.76 m 30.0 in
<b>Draft</b>	0.71 m 28.0 in
<b>Section Lengths</b>	33.5 m 110ft
<b>Ballast Galvanized Chain</b>	12.7 mm 1/2"
<b>Chamber Length</b>	4.77 m 188 in
<b>End Connector</b>	ASTM
<b>Weight with chain</b>	15.0 Kg/m 10.1 lb/ft
<b>Material - Weight</b>	2,618 g/m <sup>2</sup> 77.0 oz/yd <sup>2</sup>
<b>Recommended Application</b>	<i>Open Water / Terminals</i>

**MATERIAL CONSTRUCTION SPECIFICATIONS**

Urethane COATED TYPE	WEIGHT	FABRIC TYPE	FABRIC PROPERTIES	TENSILE STRENGTH	HIGH / LOW TEMP
	<i>g/m<sup>2</sup></i>			<i>N/5cm</i>	<i>°C</i>
Oil & Water Resistant	2,618	Nylon	75,000 Cycles Abrasion resistance	5,780	+82 / -60
	77.0			1300	+180 / -51

**MADE IN USA**



**ISO 9001-2015  
FM 517957**

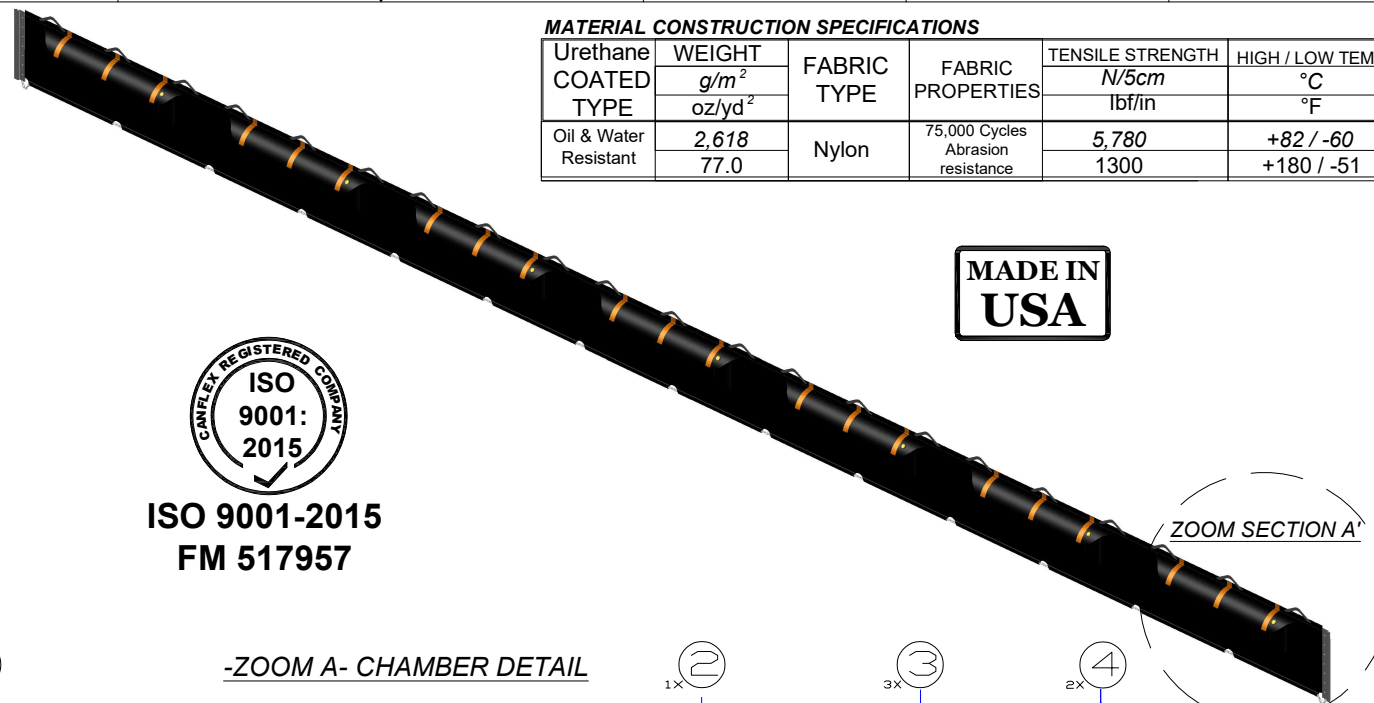

ZOOM SECTION A'

**-ZOOM A- CHAMBER DETAIL**

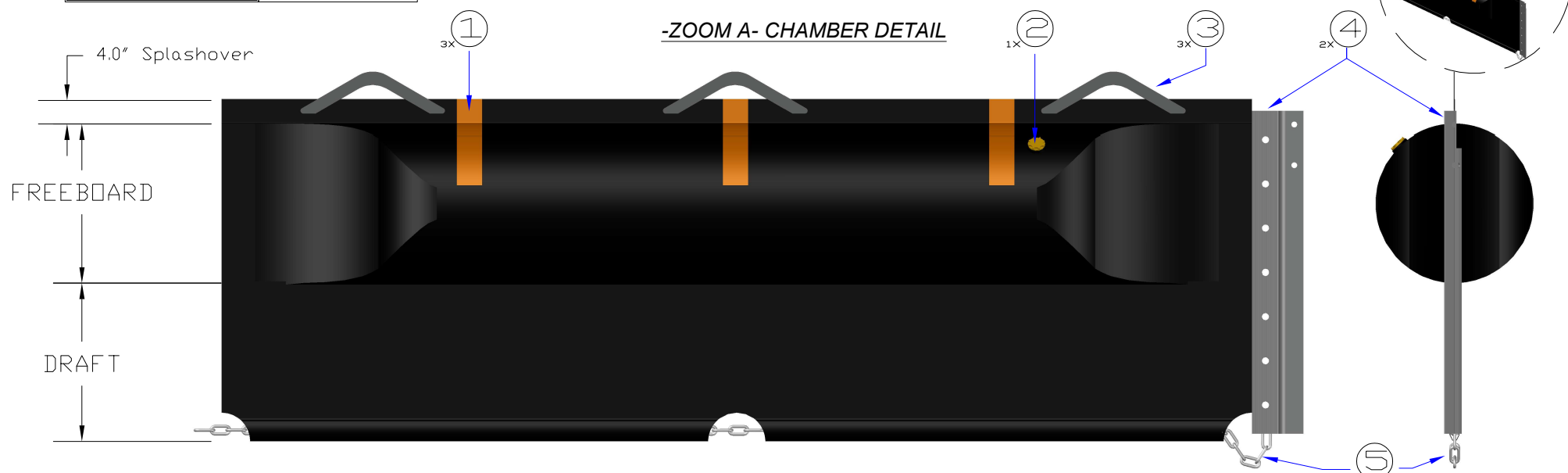

ITEM NO.	QTY. REQD.	DESCRIPTION OF ITEM PER CHAMBER	PART #
1	3	HIGH VISIBILITY STRIPS	RFLX/3
2	1	INFLATION / DEFLATION VALVE	MONSUN
3	3	500 WLL HEAVY DUTY HANDHOLD	HDL
4	2	ASTM END CONNECTORS c/w SACRIFICIAL ZINC ANODES	ASTM/1500X
5	1	1/2" BALLAST GALVANIZED CHAIN	0.5CHN



**PROJECT: OPEN WATER / TERMINALS  
CANFLEX HEAVY DUTY  
OIL SPILL CONTAINMENT BOOM**

SCALE: N.T.S  
DATE: 10/28/2021

**OCB-1500X**

DRAWN: F.Y. | DRWG #: 1021-12  
REVISED: 03/27/2022

**CANFLEX USA INC. PO BOX 1014 / 412 30th St , Anacortes,WA,98221,USA  
Tel: (206)282-8233; Email: salesteam@canflexinc.com Web: www.canflexinc.com**