

CANFLEX MODEL QUAD/3400
3400 gal Bladder System with Quadcon Containers

The 3400 gal fluid storage system “QUAD/3400” consists of 4 x fuel rated rectangular bladders with Secondary 8 bulkheads and auxiliary equipment and the optional 4 x Quadcon containers.

1.0 Fuel rated Rectangular shaped Bladder – CRT-850

The material used for the fabrication of the bladder CANFLEX Rectangular Tank “CRT” meets the requirements for containment of hydrocarbons / Diesel Fuel, Oil Spill per MIL-PRF-32233. This fabric has a total weight of 45.0 oz/sq. yd. (1530 g/ m²), with the strength characteristics shown in Table-2 below. All seams used to construct the CPT are R/F welded with a 2.5" and 4" die. **No sewing or gluing shall be used.** The resulting seam strength of the welds is equal to or greater than the strength of the parent fabric.

Table 1 Characteristics

Model	Capacity	Filled Dimension			Dry Weight without accessories
		I	W	H	
	m³ / Barrels	m	m	m	Kg
Gallons (USA)	ft	ft	ft	Lb	
CRT-850	3.2 / 20.2	1.24	2.13	1.42	36.36
	850	49	84	56	80

1.1 Fittings and Items (bolted , welded)

The Tank fittings are made from cast anodized marine grade aluminum. Nuts, bolts, and washers integral to the fittings are made of stainless steel. The fittings are bolted through the main body of the Pillow Tank to a cast marine grade aluminum backing plate. Each fitting is mounted on a patch having a greater diameter than the outside diameter of the particular fitting (anti-chafe patch).

- One bolted 2” NPT connection c/w male swivel camlock, located on the top end of the tank.
Purpose: Filling / Offloading connection
- One bolted 2” NPT connection c/w male camlock, located on the top center of the tank.
Purpose: Pressure release vents
- Six handles welded on top of the Tank. **Purpose: To help set-up and positioned the tank before the filling process.**
- One welded degradation marker that consists of 10 test strips (2”x8”) made of the same pattern material as the tank’s body. The strips are welded on a rectangular patch, which is welded on exterior top of the tanks.
Purpose: To quantify the degradation of the fabric and weld strength over time.
- One bolted pouch with Velcro / buckle securing assembly
Purpose: To stow spark arrestor assembly.

Table 2 - Material Strength Results
For Oil Spill / Hydrocarbons / Fuel: CANFLEX CFL4590NESU

1.0 BASE FABRIC

1.1	Base Fabric Weight	14 oz/yd ²	476 g/m ²
1.2	Fiber / Style	Nylon / Style 90	

2.0 COATED FABRIC

2.1	Total Weight	45 <u>+2</u> oz/yd ²	1530 <u>+68</u> g/m ²
2.2	Coating Type	Urethane	
2.3	Coating Distribution	50/50	
2.4	Sealing Properties	<input checked="" type="checkbox"/> Dielectric	<input checked="" type="checkbox"/> Thermal

3.0 MATERIAL PROPERTIES	<u>Standard</u>	<u>Metric</u>	ASTM TEST METHODS
--------------------------------	------------------------	----------------------	--------------------------

3.1	Tensile Strength, 1" Strip			
	Warp	700 lbs	3,110 N	D751-B
	Fill	650 lbs	2,890 N	
3.2	Tear Strength, Tongue			
	Warp	55 lbs	245 N	D751-B (mod)
	Fill	55 lbs	245 N	
3.3	Puncture, Screwdriver	225 lbs	1,000 N	D751
3.4	Ply Adhesion	40 lbs/2 in	178 N/5 cm	D751 (mod)
3.5	Adhesion, RF	40 lbs/in	70 N/cm	D751
3.6	Adhesion, Thermal	40 lbs/in	70 N/cm	D751
3.7	Low Temp	-50 °F	-46 °C	D2136
3.8	High Temp, Cont/Interm.	160 / 180 °F	71 / 82 °C	D1204

Comments: This product designed for primary containment of fuel per / MIL-PRF-32233

1.2 List of all unattached accessories included with the Tank

- 1 X 2" x 90° elbow female x male camlok connection.
- 1 X 2" ball valve w/ male & female camlock (pin & lanyard configuration) and dust cap
Purpose: Filling / Offloading.
- 1 X Spark /Flame Arrestor with 2" aluminum anodized pipe (customed made to a low profile) in accordance with MIL specs. It is located at center top of the tank. **Purpose: Spark Arrestor/ Pressure release vent.**
- 1 X 2" ball valve w/ male & female camlock (pin & lanyard configuration) and dust cap
Purpose: Attached to center 2" NPT connection & Spark Arrestor above
- Shipping / Storage carry bag (details below)
- One maintenance kit that contains following items:
 - 1 x 8 oz. Can PVC patch cement
 - 2 x 7" circles same
 - 4 x 4" circles same
 - 1 knife
 - 1 roller for patch cement
 - User CRT Operation MANUAL
 - 6 x bungees to secure liner to bulkhead

CRT-850 inside Quadcon



CRT-850 Pressure & Volume Test Outside Quadcon



2.0 Fuel Rated Secondary Containment- LNR-QUAD/CONT

The Secondary Containment is a liner made of 16 mil fuel rated Urethane material, that wraps around the tank and on the sides of the bulkead. The purpose of this liner is to contain any spill that may occur during the filling/ offloading process.

The liner has been tailored with a Buckle Clip system to help secure around the CRT-850 and hold down bungees to secure to the bulkeads.

All seams used to construct the liner are R/F welded. **No sewing or gluing shall be used.** The resulting seam strength of the welds is equal to or greater than the strength of the parent fabric.

Secondary Containment/ Liner outside Quadcon



LNR-QUAD/CONT inside Quadcon



3.0 Bulkhead for Quad Container- 60BKHD/2

The bulkhead assembly fits with the standard Quadcon dimensions and is fabricated of steel & plywood. It comes with pull handles for ease installation and 1/4" eyebolts for securing the liner's bungees.

The bulkhead has a tapered bottom corners to allow to sit flush at the bottom of the container and a foot for stability. The foot is wrap with high strength material to prevent abrasions when in contact with the liner.



4.0 Shipping, Transportation and Packing OPTIONS

OPTION 1:

Shipping /storage container Clip-Lok heavy marine grade plywood

PART#: CFX2

It contains the following items:

- 4 x CRT-850 fuel bladder
- 4 x LNR-QUAD/CONT secondary containment
- All unattached accessories mentioned on section 1.2

Characteristics:

- Clip-lok style plywood box capable of housing the tank and all its accessories.
- Made of ¾” Heat Treat Marine Grade plywood comply with ISPM 15 standards, certified for International Exports.
- Quickly assembled or taken apart with no nails or screws.
- Two air vents with screen for air circulation
- Easily and quickly flat-packed, reducing transport and storage volume
- Forklift slots on all sides
- Suitable for transport by road, rail, sea or air.
- Weather resistance epoxy paint coating
- Dimensions: 45x48x53”H
(1.14m X 1.21m X 1.32m H)
- Weight empty: 225 lbs (102 Kg)



OPTION 2:

Shipping /storage container Clip-Lok heavy marine grade plywood

PART#: CFX4

It contains the following items:

- 4 x CRT-850 fuel bladder
- 4 x LNR-QUAD/CONT secondary containment
- All unattached accessories mentioned on section 1.2
- 8 x - 60BKHD/2- Bulkhead for Quad Container

Characteristics:

- Clip-lok style plywood box capable of housing the tank and all its accessories.
- Made of ¾" Heat Treat Marine Grade plywood comply with ISPM 15 standards, certified for International Exports.
- Quickly assembled or taken apart with no nails or screws.
- Two air vents with screen for air circulation
- Easily and quickly flat-packed, reducing transport and storage volume
- Forklift slots on all sides
- Suitable for transport by road, rail, sea or air.
- Weather resistance epoxy paint coating
- Dimensions: 88x76x62"H (2.23m X1.93m X 1.57m H)
- Weight: 700 lbs (315 Kg)



OPTION 3:

Marine Grade aluminum shipping /storage container

PART#: ALCNT2

The container is made of marine grade anodized aluminum 6011-T6. It can be safely lifted with a crane or helicopter using the certified lifting straps with shackles via the lifting points, or with a forklift via the forklift slots.

It contains the following items:

- 4 x CRT-850 fuel bladder
- 4 x LNR-QUAD/CONT secondary containment
- All unattached accessories mentioned on section 1.2

Characteristics:

- Two screened air vents
- Cable hoist lifting points (8)
- Fork lift slots on all sides
- Fold down and removable side door
- Locking lid
- 2" bottom drain w/ male camlock
- Aluminum Container Accessory Kit (ALCNT-KIT 2)
- OD: 1.62m X 1.62m X 1.35m High
(64" X 64" X 53.5" High)
- Volume: 2.83 m3 (100 ft3)
- Weight: 235 Kg (520 lb); WLL: 2900 Kg (6400 lbs)
- Dimensions: 45x48x29"H
(1.14m X1.21m X 0.73m H)



OPTION 4:

Marine Grade aluminum shipping /storage container

PART#: ALCNT3

The container is made of marine grade anodized aluminum 6011-T6. It can be safely lifted with a crane or helicopter using the certified lifting straps with shackles via the lifting points, or with a forklift via the forklift slots.

It contains the following items:

- 4 x CRT-850 fuel bladder
- 4 x LNR-QUAD/CONT secondary containment
- All unattached accessories mentioned on section 1.2
- 8 x - 60BKHD/2- Bulkhead for Quad Container

Characteristics:

- Two screened air vents
- Cable hoist lifting points (8)
- Fork lift slots on all sides
- Fold down and removable side door
- Locking lid
- 2" bottom drain w/ male camlock
- Aluminum Container Accessory Kit (ALCNT-KIT 3)
- OD: 2.54m X 1.9m X 1.46m High
(100" X 75" X 57.5" High)
- Volume: 5.7 m3 (201 ft3)
- Weight: 345 Kg (760 lb); WLL:5,700 Kg (12,500 lbs)



5.0 Quadcon Cry Fright ISO Cargo Container- QUADCON (Optional Item)

The CANFLEX QUAD/3400 system is for 4 x QUADCONs with the following features:

- Manufactured to ISO standards for 9 high staking
- Dry freight container, all corten steel monocoque construction
- Conforming to ISO 668 + 1496 CSC Certified
- 4 Quadcon Containers coupled together to form (1) 20ft ISO module.

Table 4 Characteristics

Model	Capacity	Exterior Dimension			Gross Weight
		W	L	H	
	m ³	m	m	m	Kg
ft ³	ft-in	ft-in	ft-in	Lb	
QUADCON	6.17	1.457	2.438	2.082	5,080
	217.8	4'- 9-3/8"	8'-0"	6'-10"	11,200



6.0 Labels :

- Size and function of all aluminum fittings (i.e., FILL/DRAIN ; DRAIN , VENT)
- Safety and Warning Labels
- CANFLEX ID label screened with Serial Number and Tank capacity
- Label screened on opposite sides with either Customer or Canflex name

7.0 Certifications & Pressure Test

- Each Tank is pressure tested according to our Quality Management System ISO-9001-2015
- CANFLEX (USA) INC operates a Quality Management System which complies with the requirements of ISO 9001-2015. CANFLEX (USA) INC holds Certificate No: FM 517957

Specifications

MODEL	CAPACITY	WIDTH	LENGTH	HEIGHT	FILL / OFFLOAD Quantity	VENT Quantity
	<i>m³ / Liters</i> Gallons USA	<i>m</i> inches	<i>m</i> inches	<i>m</i> inches		
CRT-850	3.2 / 3200	1.24	2.13	1.42	1	1
	850	49	84	56		

FUEL rated fittings:

FLANGES: Anodized aluminum with Stainless Steel fasteners
 CAMLOCK: (Cam & Groove quick coupling): Anodized Aluminum
 Female camlocks with safety pin & lanyard
 Ball Valve: rated for fuel
 Gaskets: BUNA N (Fuel)



**ISO 9001-2015
FM 517957**

MODEL	*WEIGHT EMPTY Lb	**WEIGHT FULL Lb
CRT-850	80	7,090

*Aproximated weight
 **Weight calculated using water density @ 62.4 lbs/ft3

MATERIAL CONSTRUCTION SPECIFICATIONS

*URETHANE COATED TYPE	WEIGHT	FABRIC TYPE	FABRIC PROPERTIES	TENSILE STRENGTH	TEAR RESISTANCE
	<i>g/m²</i> <i>oz/yd²</i>			<i>N</i> lbs	<i>N</i> lb
Hydrocarbons	1,530	Nylon	Coat: 50/50 Thickness: 65 mils	3,340	290
	45.0			750	65

*This fabric designed for contact and containment of Hydrocarbons (Diesel, JP8, etc) as per MIL-T-52983

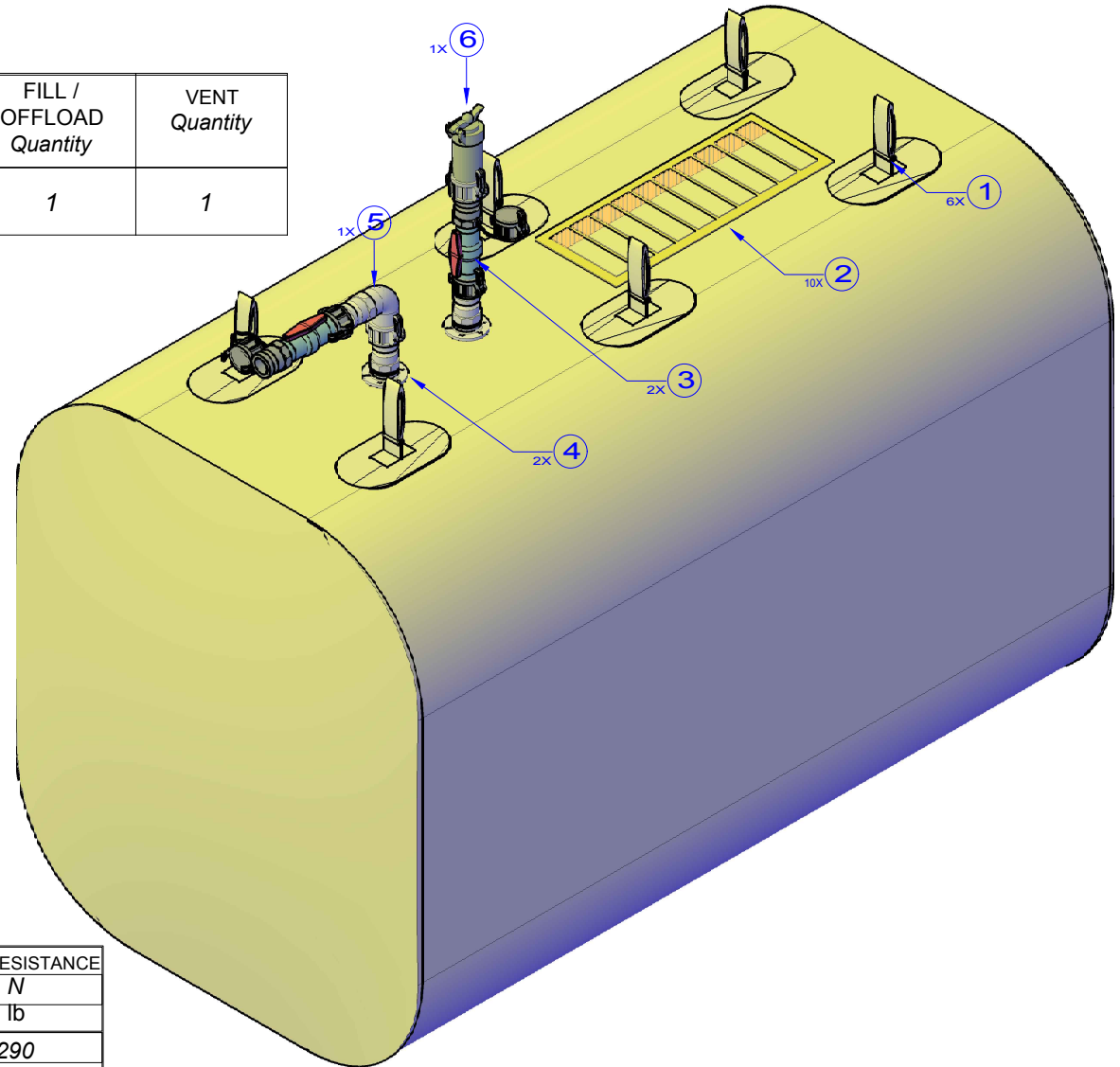

ITEM NO.	QTY. REQD.	DESCRIPTION	PART #
1	6	225 KG (500 LB) WLL- HEAVY DUTY HANDHOLD W/ 2" WEBBING	HDL
2	10	TEST TABS MADE OF PATTERN MATERIAL	TEST/TAB
3	2	2" PVC BALL VALVE W/ MALE & FEMALE CAMLOCKS & DUST CAP	BV/PVC20E/F-V
4	2	2" NPT FLANGE WITH MALE SWIVEL CAMLOCK	6X2FL/20A-SWL
5	1	90° ELBOW WITH MALE & FEMALE CAMLOCKS	20CAL
1	1	PRESSURE - VENT & SPARK ARRESTOR (MIL SPECS)	SPRK/2X10
NOT SHOWN	1	SHIPPING / CARRY STORAGE BAG	CB/L
NOT SHOWN	1	POUCH WITH VELCRO AND BUCKLE (HOLDS SPARK ARRESTOR)	PCH
NOT SHOWN	1	TOOL BOX REPAIR KIT W/ OPERATIONAL MANUAL	RPR/KIT-CRT-FU



PROJECT: 850 gal RECTANGULAR SHAPED TANK FOR FOR QUAD CONTAINER "NAVFAC"

SCALE: N.T.S | DATE: 09/09/2019 | **CRT-850** | DRAWN: F.Y. | DRWG #: 0820-06 | REVISED: 08/26/2020

CANFLEX USA INC. PO BOX 1014 , 412 30th St , Anacortes,WA,98221,USA
 Tel:(206)282-8233 ; Web: www.canflexinc.com

SIDE VIEW

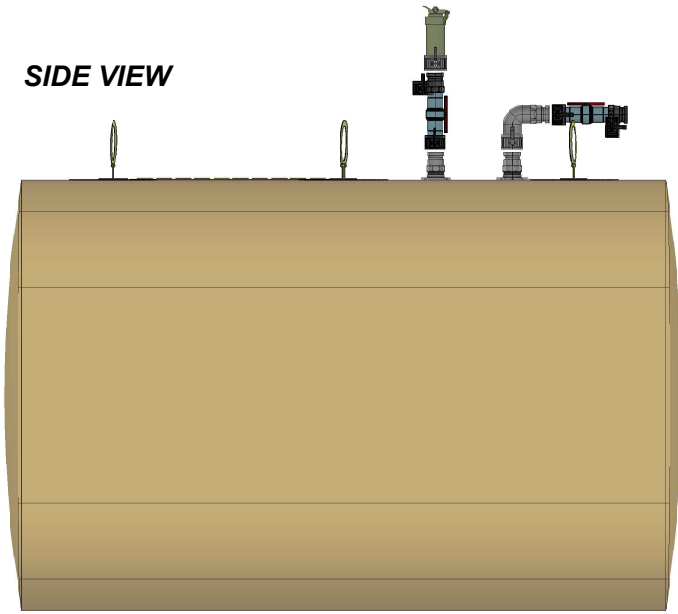

ISOMETRIC VIEW

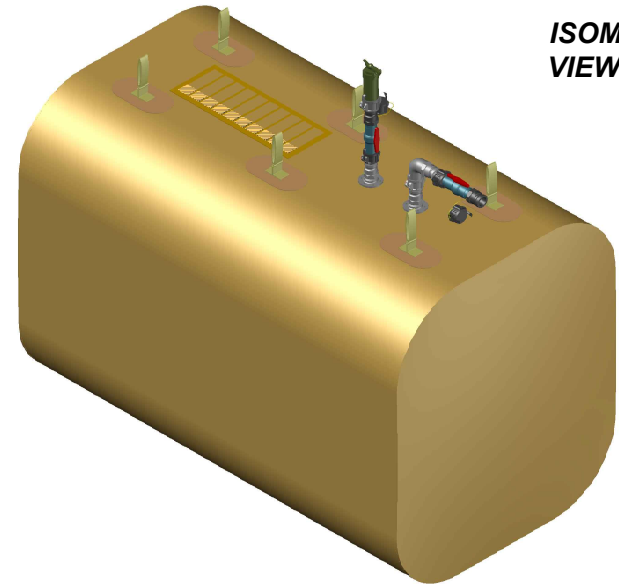

FRONT VIEW

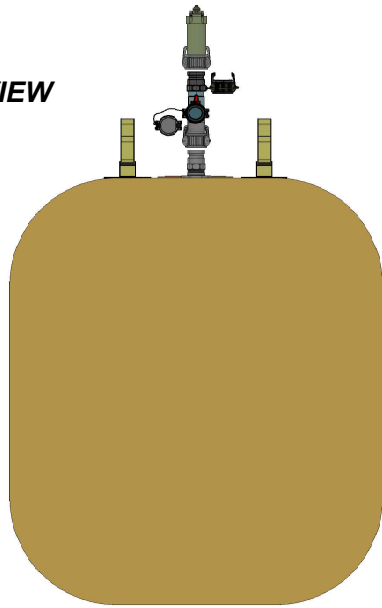

TOP VIEW

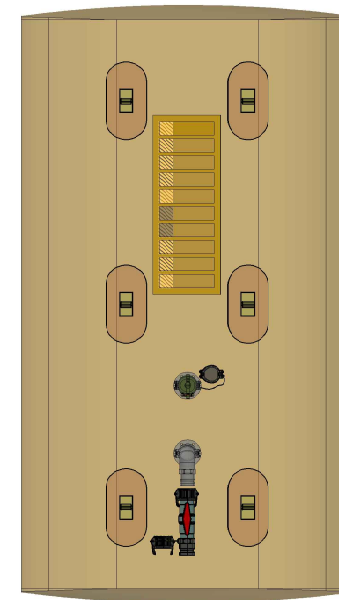

ITEM NO.	QTY. REQD.	DESCRIPTION	PART #



PROJECT: 850 gal RECTANGULAR SHAPED TANK FOR FOR QUAD CONTAINER"NAVFAC" VIEWS

SCALE: N.T.S	CRT-850	DRAWN: F.Y.	DRWG #:0820-07
DATE: 09/09/2019		REVISED: 08/26/2020	

**CANFLEX USA INC. PO BOX 1014 , 412 30th St , Anacortes,WA,98221,USA
Tel:(206)282-8233 ; Web: www.canflexinc.com**

Specifications

MODEL	WIDTH	LENGTH	HEIGHT
	<i>m</i> inches	<i>m</i> inches	<i>m</i> inches
LNR-QUAD CONT	1.52	2.23	1.82
	60	88	72



ISO 9001-2015
FM 517957

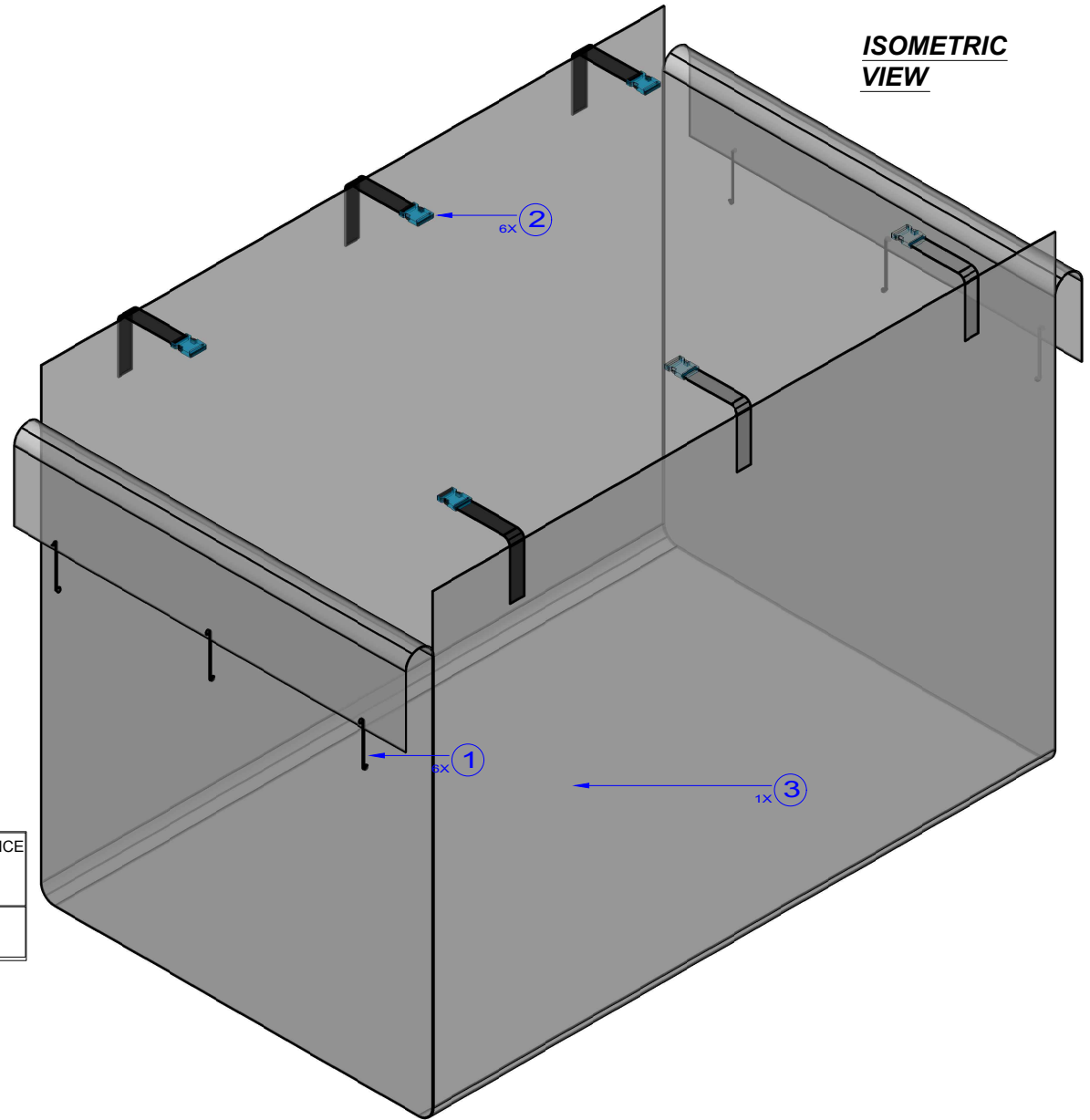

MATERIAL CONSTRUCTION SPECIFICATIONS

*URETHANE TYPE	WEIGHT <i>mm</i>	Specific Gravity D-792	YIELD <i>ft /lb @ 1mil</i>	TENSILE STRENGTH D-2240 <i>PSI</i>	TEAR RESISTANCE D-1004 <i>PSI</i>
Hydrocarbons	16.00	1.21	157	11,000	178 40

*This fabric designed for contact and containment of Hydrocarbons (Diesel, JP8, etc)

ITEM NO.	QTY. REQD.	DESCRIPTION	PART #
1	6	1/2" BUNGEEs W/ HOOKS FOR LINER ATTACHMENT TO CONTAINER WALL	BNG-8
2	6	STRAP WITH BUCKLE SYSTEM	BCK/12
3	1	LINER FOR CRT-850 TANK	LNR/CRT-850



PROJECT: FUEL RATED LINER FOR QUAD CONTAINER "NAVFAC"

SCALE: N.T.S	LNR-QUAD/CONT	DRAWN: F.Y.	DRWG #: 0820-04
DATE: 09/09/2019		REVISED: 08/26/2020	

CANFLEX USA INC. PO BOX 1014 , 412 30th St , Anacortes, WA, 98221, USA
Tel: (206) 282-8233 ; Web: www.canflexinc.com

SIDE VIEW

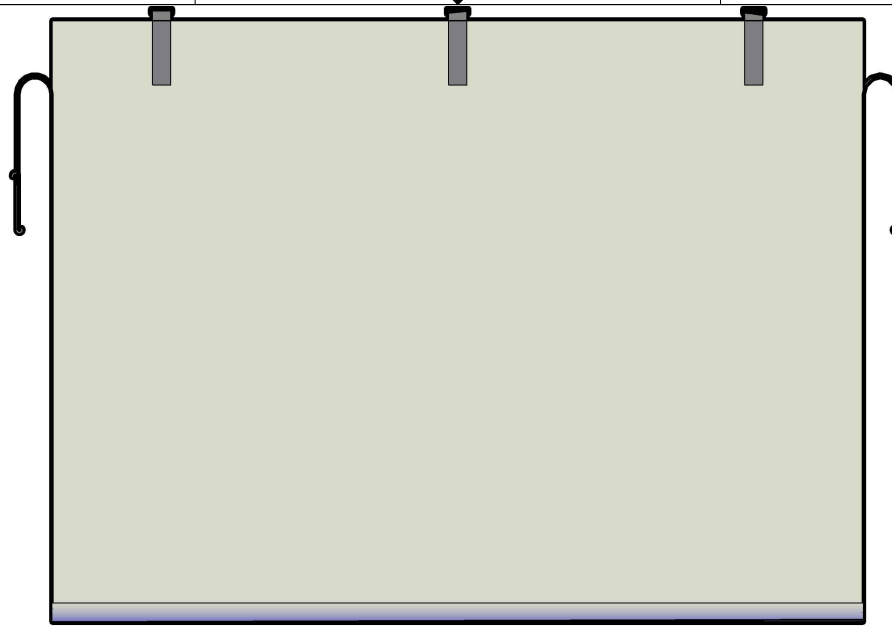

FRONT VIEW

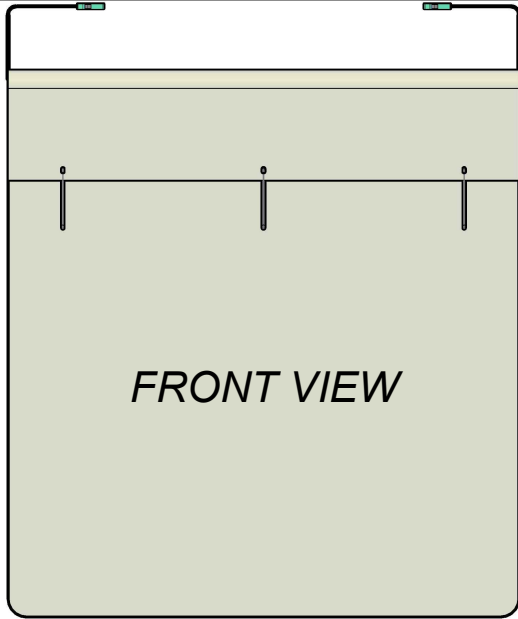

TOP VIEW

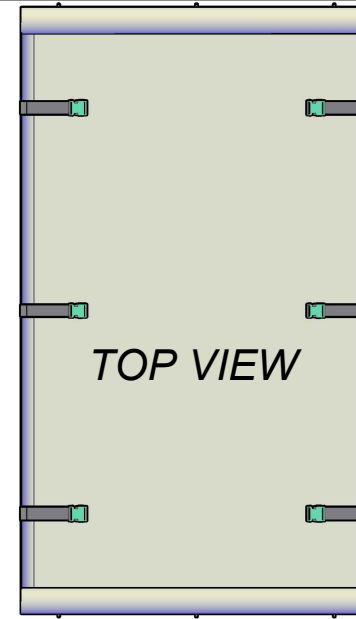

ITEM NO.	QTY. REQD.	DESCRIPTION	PART #



**PROJECT: FUEL RATED LINER
FOR QUAD CONTAINER "NAVFAC"**

SCALE: N.T.S

LNR-QUAD/CONT

DRAWN: F.Y. DRWG #: 0820-05

DATE: 09/09/2019

REVISED: 08/26/2020

CANFLEX USA INC. PO BOX 1014 , 412 30th St , Anacortes, WA, 98221, USA
Tel: (206) 282-8233 ; Web: www.canflexinc.com

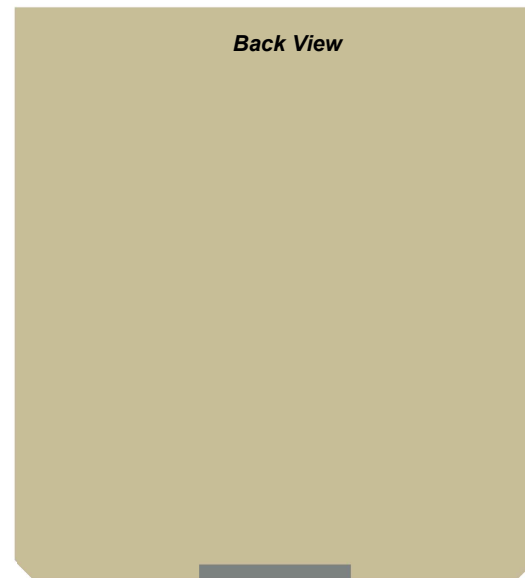
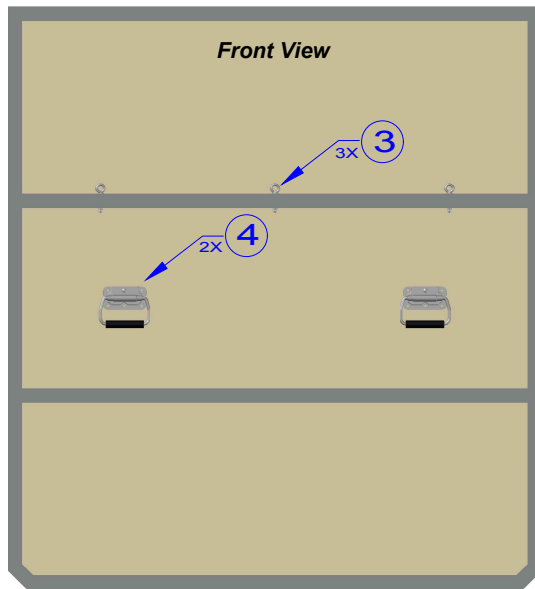
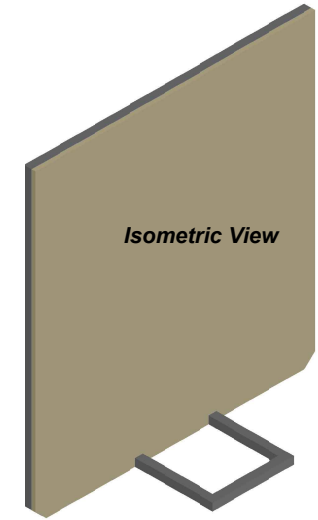
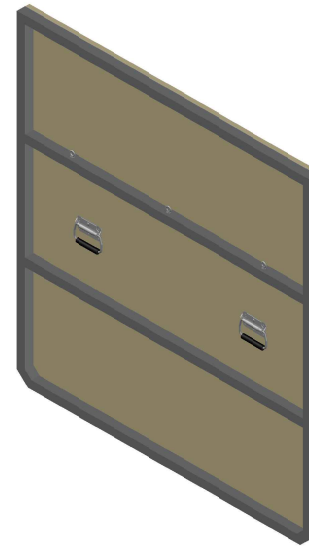
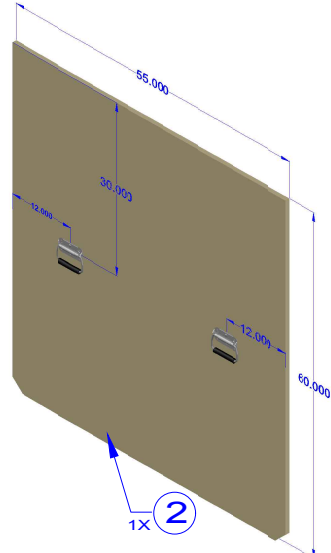
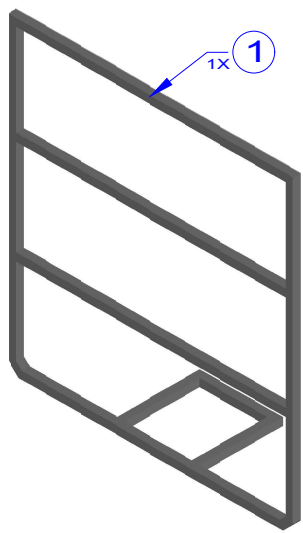

Specifications

MODEL	*WIDTH	LENGTH	HEIGHT
	<i>m</i>	<i>m</i>	<i>m</i>
	inches	inches	inches
60-BKHD/2	0.57	1.4	1.52
	2.25	55	60

*Width with Frame & Plywood: 2.25"
Width with base: 17.5"

ITEM NO.	QTY. REQD.	DESCRIPTION	PART #
1	1	FRAME 55X 60X 1.5 STEEL TUBING	60-FRM
2	1	3/4" PLYWOOD CUSTOM SIZE	60X48 PLY
3	3	1/4" EYEBOLT WITH WASHER, LOCK WASHER & NUT	0.25EB
4	2	4" FODING PULL HANDLE	HDL/4PULL



PROJECT: CRT-850 SYSTEM
BULKHEAD FOR QUAD CONTAINER

SCALE: N.T.S	60BKD/2	DRAWN: F.Y.	DRWG #: 0820-08
DATE: 09/09/2019		REVISED: 08/26/2020	

CANFLEX USA INC. PO BOX 1014 , 412 30th St , Anacortes,WA,98221,USA
Tel:(206)282-8233; Web: www.canflexinc.com

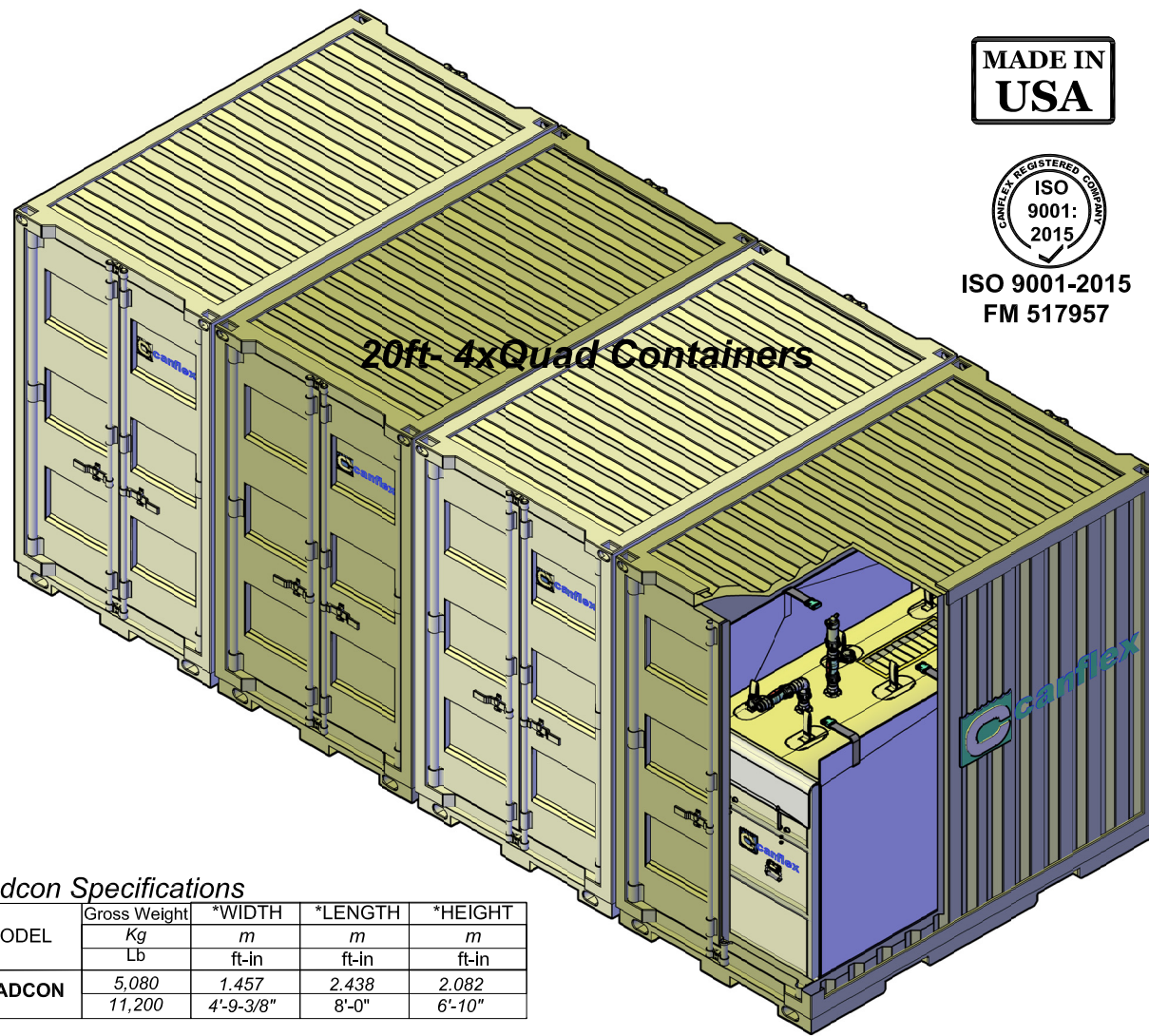

MADE IN USA



ISO 9001-2015
FM 517957

*CRT-850 Bladder
with Quad Container*

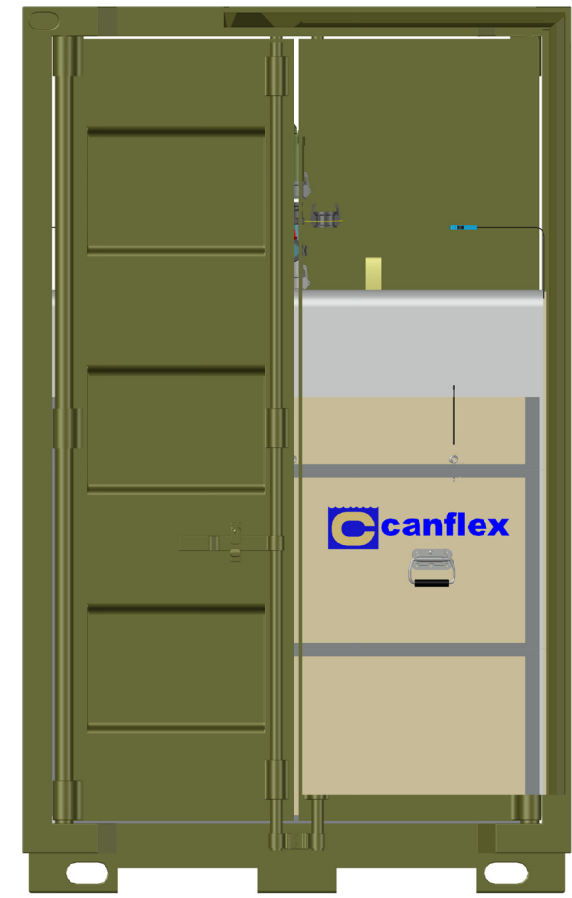

20ft- 4xQuad Containers

Quadcon Specifications

MODEL	Gross Weight	*WIDTH	*LENGTH	*HEIGHT
	Kg Lb	m ft-in	m ft-in	m ft-in
QUADCON	5,080	1.457	2.438	2.082
	11,200	4'-9-3/8"	8'-0"	6'-10"

20ft (4x Quadcon) Specifications

MODEL	**CAPACITY	*WIDTH	*LENGTH	*HEIGHT
	m ³ / Barrels	m	m	m
	Gallons USA	ft-in	ft-in	ft-in
QUAD/3400	12.87 / 81	2.438	6.058	2.082
	3400	8'-0"	20'-0"	6'-10"

*External Dimensions
**Capacity with 4 x CRT-850 bladders

Bladder Specifications

MODEL	CAPACITY	WIDTH	LENGTH	HEIGHT	FILL / OFFLOAD Quantity	VENT Quantity
	m ³ / Liters Gallons USA	m inches	m inches	m inches		
CRT-850	3.2 / 3200	1.24	2.13	1.42	1	1
	850	49	84	56		



PROJECT: 3400 gal System with Quadcon Containers

SCALE: N.T.S	QUAD/3400	DRAWN BY: F.Y.
DATE: 09/09/2019		REVISED:

CANFLEX USA INC. PO BOX 1014 , 412 30th St , Anacortes, WA, 98221, USA
Tel: (206) 282-8233 ; Web: www.canflexinc.com