

CANFLEX MODEL CRT-1500
Rectangular Shaped Tank for Transport on MTRV or LVSR vehicles

1.0 Introduction

The CRT-1500 is a Canflex Rectangular shape Tank “CRT” designed to be placed on a flatbed configuration of a MTRV or LVSR vehicle.

The CRT primary function is to store and dispense fuel.

This bladder has tie down harness to secure the bladder to the truck’s bed, a lateral strap webbing harness integrated on the the bladder and a internal baffling system in both longitudinal and radial directions.



2.0 Fuel rated Rectagular shaped Bladder – CRT-1500

The material used for the fabrication of the Canflex Rectangular shaped Tank (CRT) meets the requirements for containment of hydrocarbons / Diesel Fuel, Oil Spill per MIL-PRF-32233. This fabric has a total weight of 45.0 oz/sq. yd. (1530 g/ m²), with the strength characteristics shown in Table-2 below. All seams used to construct the CRT are R/F welded with a 2.5" and 4" die. **No sewing or gluing shall be used.** The resulting seam strength of the welds is equal to or greater than the strength of the parent fabric.

Table 1 Characteristics for CANFLEX “Rectangular Shaped Tank”

Model	Capacity	Filled Dimension			Dry weight w/o accessories
		W	L	H	Aprox. Weight
	m ³ / Barrels	m	m	M	Kg
Gallons US	inches	inches	Inches	Lb	
CRT-1500	5.67 / 35.7	1.72	5.48	0.61	181
	1,500	68	216	24	400

3.0 Fittings and Items (bolted , welded)

The Tank fittings are made from cast anodized marine grade aluminum. Nuts, bolts, and washers integral to the fittings are made of stainless steel. The fittings are bolted through the main body of the Pillow Tank to a cast marine grade aluminum backing plate. Each fitting is mounted on a patch having a greater diameter than the outside diameter of the particular fitting (anti-chafe patch).

- One 2” NPT connection c/w male camlok, located at the lower edge of the tank.
Purpose: Filling / Offloading connection
- One x 2” NPT female connection c/w female camlok, located across the top of the tank.
Purpose: Pressure release vent
- 2 x Pocket / sleeves welded on the longitudinal direction of the tank.
Purpose: Enclosed polyester webbing straps
- One welded degradation marker that consists of 10 test strips (2”x8”) made of the same pattern material as the tank’s body. The strips are welded on a rectangular patch, which is welded on exterior top of the tanks.

Purpose: To quantify the degradation of the fabric and weld strength over time.

**Table 2 - Material Strength Results
CANFLEX CFL4590NESU**

1.0 BASE FABRIC

1.1	Base Fabric Weight	14 oz/yd ²	476 g/m ²
1.2	Fiber / Style	Nylon / Style 90	

2.0 COATED FABRIC

2.1	Total Weight	45 <u>±</u> 2 oz/yd ²	1530 <u>±</u> 68 g/m ²
2.2	Coating Type	Urethane	
2.3	Coating Distribution	50/50	
2.4	Sealing Properties	<input checked="" type="checkbox"/> Dielectric	<input checked="" type="checkbox"/> Thermal

3.0 MATERIAL PROPERTIES

		<u>Standard</u>	<u>Metric</u>	ASTM TEST METHODS
3.1	Tensile Strength, 1" Strip			
	Warp	700 lbs	3,110 N	D751-B
	Fill	650 lbs	2,890 N	
3.2	Tear Strength, Tongue			
	Warp	55 lbs	245 N	D751-B (mod)
	Fill	55 lbs	245 N	
3.3	Puncture, Screwdriver	225 lbs	1,000 N	D751
3.4	Ply Adhesion	40 lbs/2 in	178 N/5 cm	D751 (mod)
3.5	Adhesion, RF	40 lbs/in	70 N/cm	D751
3.6	Adhesion, Thermal	40 lbs/in	70 N/cm	D751
3.7	Low Temp	-50 °F	-46 °C	D2136
3.8	High Temp, Cont/Interm.	160 / 180 °F	71 / 82 °C	D1204

Comments: This product designed for primary containment hydrocarbons per / MIL-PRF-32233

4.0 List of all unattached accessories included with the Tank

CANFLEX (USA) INC
412-30th. Street -P.O. Box 1014-ANACORTES WASHINGTON 98221
Tel: (206) 282-8233 ; canflex@direct.ca; www.canflexinc.com

- 1 X 2" x 90° elbow female x male camlok connection.
- 1 X 2" ball valve w/ female & male camlock conn. with cap, to attach to above elbow.
Purpose: Filling / Offloading
- 1 X Spark /Flame Arrestor with 2" x 10" aluminum anodized pipe , in accordance with MIL specs. It is located at center top of the tank.
Purpose: Spark Arrestor/ Pressure release vent.
- 1 X 2" ball valve w/ male & female camlock conn. with plug, to attach to above spark arrestor / vent. **Purpose: Filling / Offloading**
- 2 x circumferential polyester webbing straps on the longitudinal direction of the tank
Purpose: Added longitudinal strenght around the tank
- 2 X 5/8" Safety shackle with bolt & cotter pin
Purpose: Hold webbing straps mentioned above
- Internal baffles in the width (4 x radial) & length (2 x longitudinal) direction of the tank.
Purpose: To reduce sloshing / dumping of fluid while transport
- 1 x Restrain System consists of 6" diameter SS "O" rings with 3" webbing straps with soft eye ends at ends.
- One maintenance kit that contains following items:
 - 1 x Tool Box (for the 4 units)
 - 1 x 8oz Can of Patch Cement with MSDS;(Not available if Air Freight)
 - 2 x 10" circles of coated bladder material;
 - 4 x 7" circles of coated bladder material;
 - 1x roller;
 - 1x knife;
 - 1 x Operational Guidelines



CRT-1500 Canflex Rectangular Tank



Internal Baffels



CRT-1500 with 2" elbow & ball valve



Internal Baffels in action – 60m/h to 0 m/h Brake Stop

5.0 Shipping, Transportation and Packing OPTIONS

OPTION 1:

Shipping /storage container Clip-Lok heavy marine grade plywood

PART#: CFX1

It contains the following items:

- 1 x CRT-1500
- All unattached accessories mentioned on section 4.0

Characteristics:

- Clip-lok style plywood box capable of housing the tank and all its accessories.
- Made of ¾" Heat Treat Marine Grade plywood comply with ISPM 15 standards, certified for International Exports.
- Quickly assembled or taken apart with no nails or screws.
- Two air vents with screen for air circulation
- Easily and quickly flat-packed, reducing transport and storage volume
- Forklift slots on all sides
- Suitable for transport by road, rail, sea or air.
- Weather resistance epoxy paint coating
- Dimensions: 45x48x29"H
(1.14m X1.21m X 0.73m H)
- Weight empty: 180 lbs (82 Kg)



OPTION 2:

Marine Grade aluminum shipping /storage container

PART#: ALCNT2

It contains the following items:

- 1 x CRT-1500
- All unattached accessories mentioned on section 4.0

Characteristics:

- Two screened air vents
- Cable hoist lifting points (8)
- Fork lift slots on all sides
- Fold down and removable side door
- Locking lid
- 2" bottom drain w/ male camlock
- Aluminum Container Accessory Kit (ALCNT-KIT 2)
- OD: 1.62m X 1.62m X 1.35m High
(64" X 64" X 53.5" High)
- Volume: 2.83 m3 (100 ft3)
- Weight: 235 Kg (520 lb); WLL: 2900 Kg (6400 lbs)
- Dimensions: 45x48x29"H
(1.14m X1.21m X 0.73m H)



6.0 Labels

- Size and function of all aluminum fittings (i.e., FILL/DRAIN ; DRAIN ,VENT)
- Safety and Warning Labels
- CANFLEX ID label screened with Serial Number and Tank capacity
- Label screened on opposite sides with either Customer Name

7.0 Certifications & Pressure Test

- Each Tank is pressure tested according to our Quality Management System ISO-9001-20015
- CANFLEX (USA) INC operates a Quality Management System which complies with the requirements of ISO 9001-2015. CANFLEX (USA) INC holds Certificate No: FM 517957

Specifications

MODEL	CAPACITY	WIDTH	LENGTH	HEIGHT	FILL / OFFLOAD Quantity	VENT Quantity
	m ³ / Liters Gallons USA	m inches	m inches	m inches		
CRT-1500	5.67 / 5678	1.72	5.48	0.61	1	1
	1,500	68	216	24		

FUEL rated fittings:

FLANGES: Anodized aluminum with Stainless Steel fasteners
 CAMLOCK: (Cam & Groove quick coupling): Anodized Aluminum
 Ball Valve: rated for fuel
 Gaskets: BUNA N (Fuel)

Hold Down System:

Certified webbing polyester straps with 6" SS rings



ISO 9001-2015
 FM 517957

ISOMETRIC VIEW

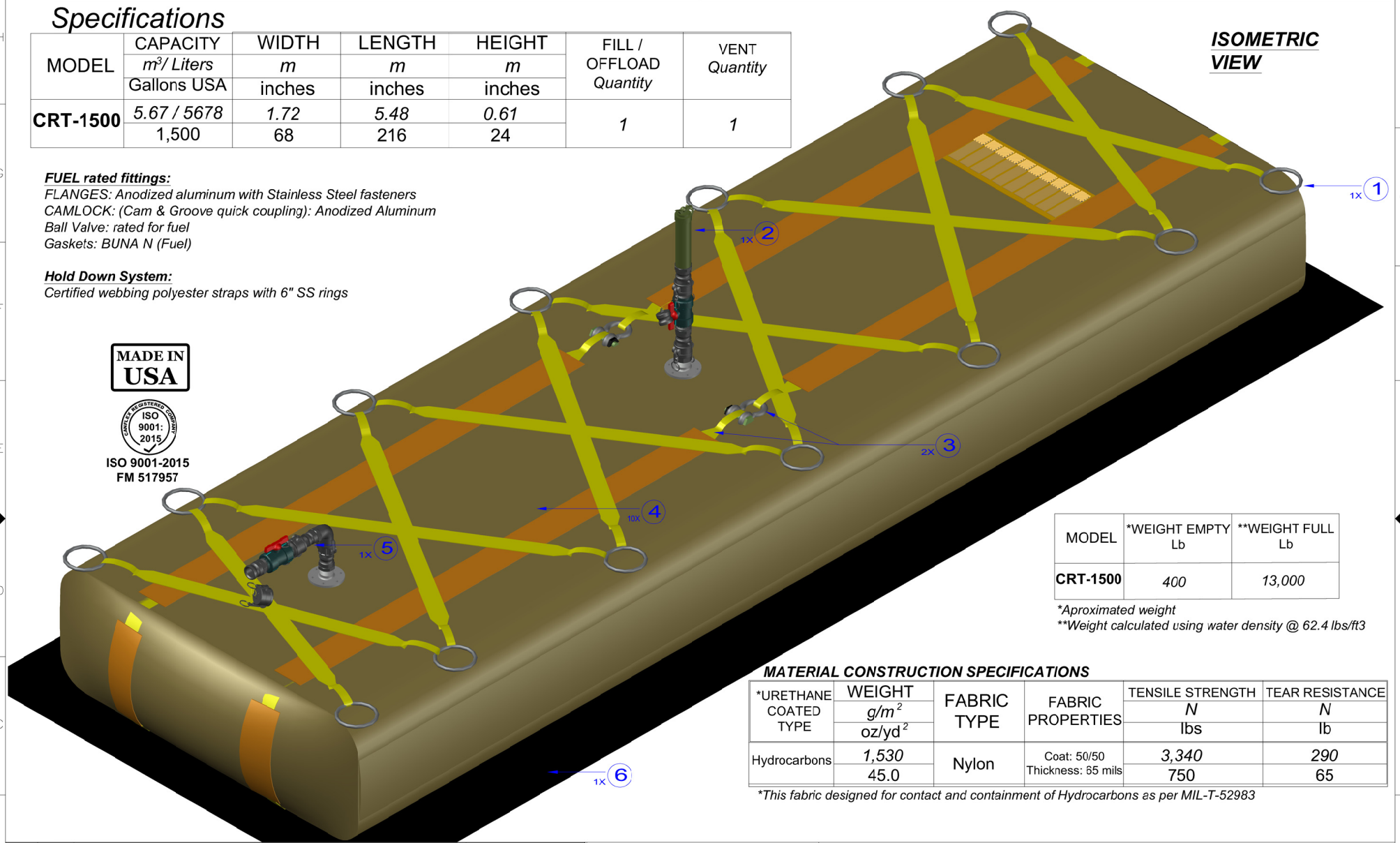

MODEL	*WEIGHT EMPTY Lb	**WEIGHT FULL Lb
CRT-1500	400	13,000

*Approximated weight
 **Weight calculated using water density @ 62.4 lbs/ft3

MATERIAL CONSTRUCTION SPECIFICATIONS

*URETHANE COATED TYPE	WEIGHT	FABRIC TYPE	FABRIC PROPERTIES	TENSILE STRENGTH	TEAR RESISTANCE
	g/m ² oz/yd ²			N lbs	N lb
Hydrocarbons	1,530 45.0	Nylon	Coat: 50/50 Thickness: 85 mils	3,340 750	290 65

*This fabric designed for contact and containment of Hydrocarbons as per MIL-T-52983

ITEM NO.	QTY. REQD.	DESCRIPTION	PART #
1	1	CERTIFIED 3" WEBBING STRAPS with "O" SS rings ASSY	3" X 6SS/1500
2	1	PRESSURE RELEASE - VENT & SPARK ARRESTOR W/ VALVE (MIL SPECS)	SPRK/2X10/BV
3	2	LATERAL 3" CERTIFIED WEBBING W/ 5/8" SAFETY SHACKLE	3" POLY/ SKL-063
4	10	TEST TABS MADE OF PATTERN MATERIAL	TEST/TAB
5	1	2" OFFLOAD / FILL PORT - BALL VALVE, ELBOW W/ CAMLOCKS & CAP	20BV/20CAL/FXB
6	1	ABRASION / GROUND SHEET (18oz PVC)	GS/234X86
NOT SHOWN	1	BUFFLE SYSTEM- RADIAL & LONGITUDINAL	BFL/1500/LXR
NOT SHOWN	1	CLIP-LOK WOOD BCX- STORAGE & TRSPORTATION (48X45X29")	CFX1



**PROJECT: RECTANGULAR SHAPED TANK FOR
 MTVR or LVSR Vehicle
 "NAVFAC"**

SCALE: N.T.S
 DATE: 12/03/2019

CRT-1500

DRAWN: F.Y. DRWG #: 0820-01
 REVISED: 12/02/2020

**CANFLEX USA INC. PO BOX 1014 , 412 30th St , Anacortes,WA,98221,USA
 Tel:(206)282-8233 ; Web: www.canflexinc.com**

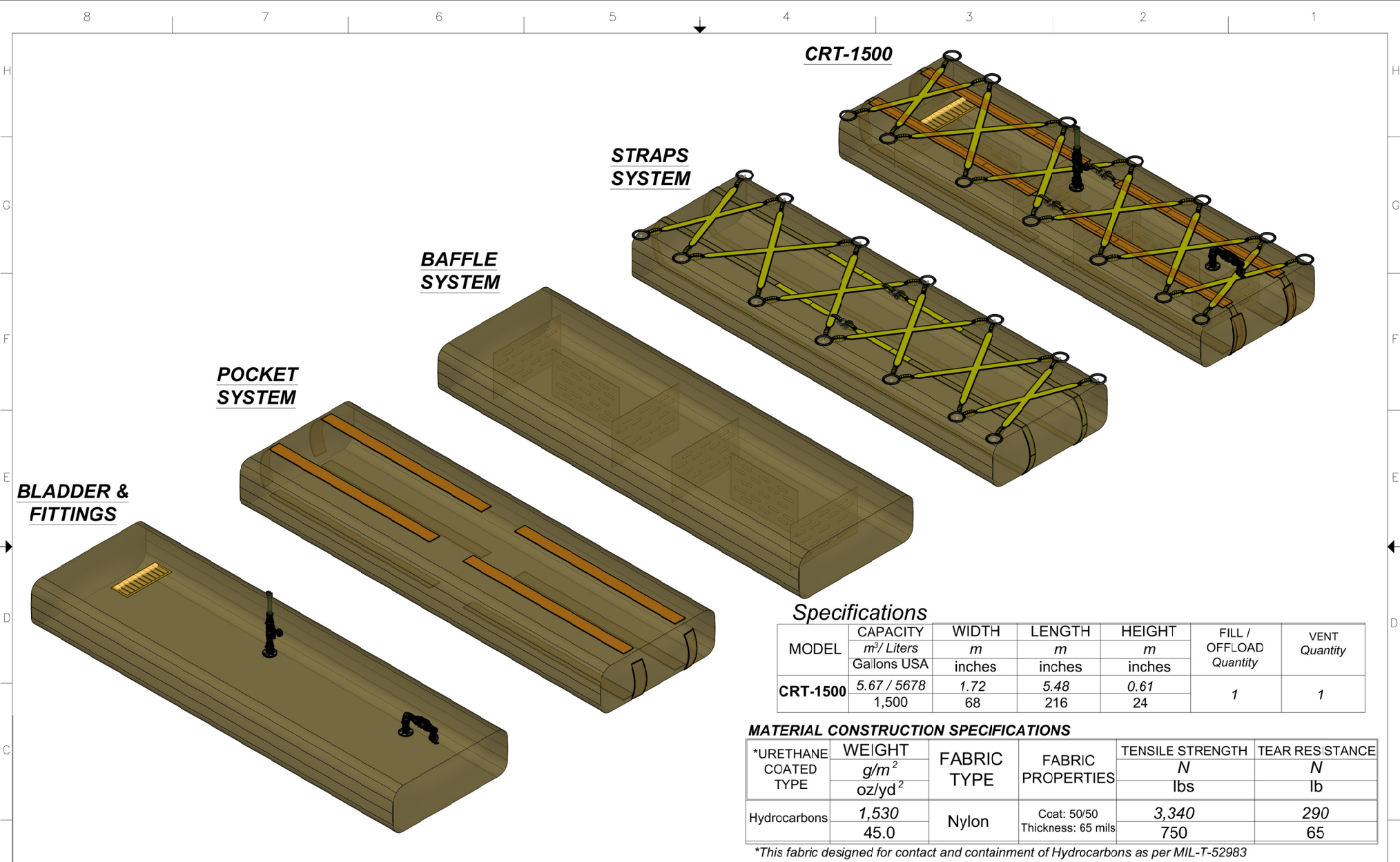

Specifications

MODEL	CAPACITY	WIDTH	LENGTH	HEIGHT	FILL / OFFLOAD Quantity	VENT Quantity
	m ³ / Liters Gallons USA	m inches	m inches	m inches		
CRT-1500	5.67 / 5678	1.72	5.48	0.61	1	1
	1,500	68	216	24		

MATERIAL CONSTRUCTION SPECIFICATIONS

*URETHANE COATED TYPE	WEIGHT	FABRIC TYPE	FABRIC PROPERTIES	TENSILE STRENGTH	TEAR RESISTANCE
	g/m ² oz/yd ²			N lbs	N lb
Hydrocarbons	1,530	Nylon	Coat: 50/50 Thickness: 65 mils	3,340	290
	45.0			750	65

*This fabric designed for contact and containment of Hydrocarbons as per MIL-T-52983

MODEL	*WEIGHT EMPTY Lb	**WEIGHT FULL Lb
CRT-1500	400	13,000

*Aproximated weight
**Weight calculated using water density @ 62.4 lbs/ft3



**PROJECT: RECTANGULAR SHAPED TANK FOR
MTVR or LVSr Vehicle
"NAVFAC"**

SCALE: N.T.S
DATE: 12/03/2019

CRT-1500

DRAWN: F.Y. DRWG #:0820-02
REVISED: 12/02/2020

**CANFLEX USA INC. PO BOX 1014 , 412 30th St , Anacortes,WA,98221,USA
Tel:(206)282-8233 ; Web: www.canflexinc.com**

CRT-1500- LATERAL VIEW

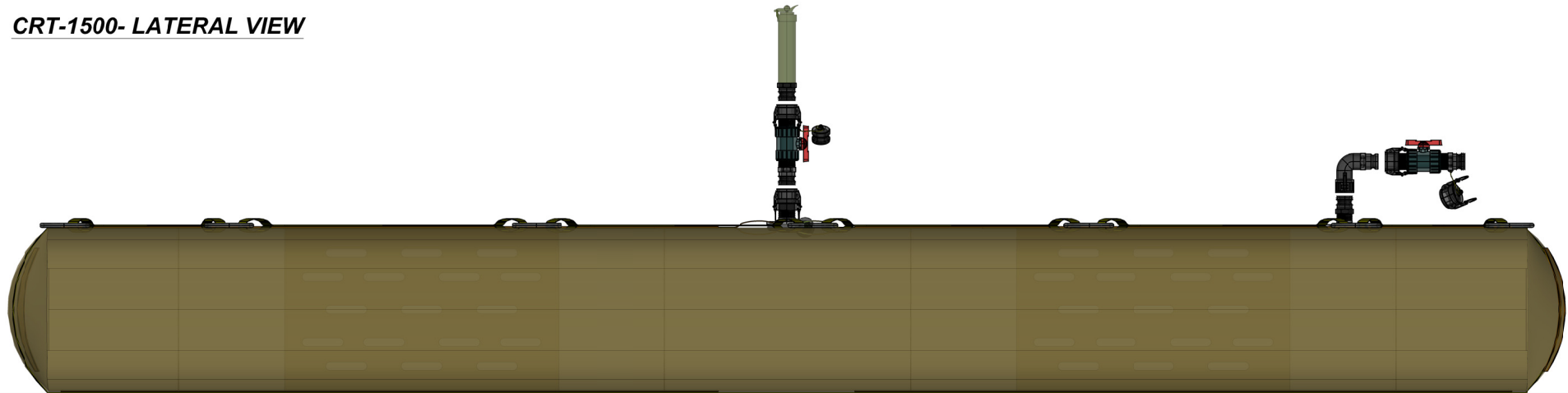

VENT

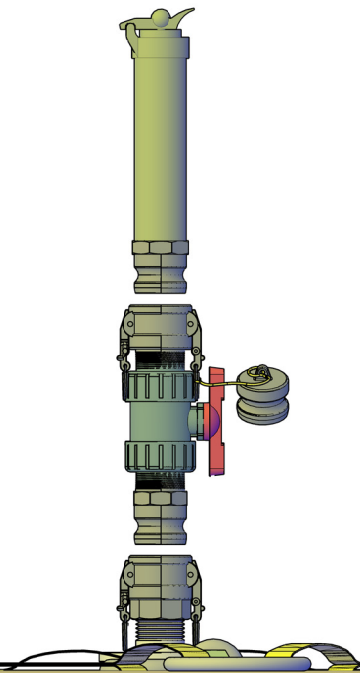

**FILL /
OFFLOAD**

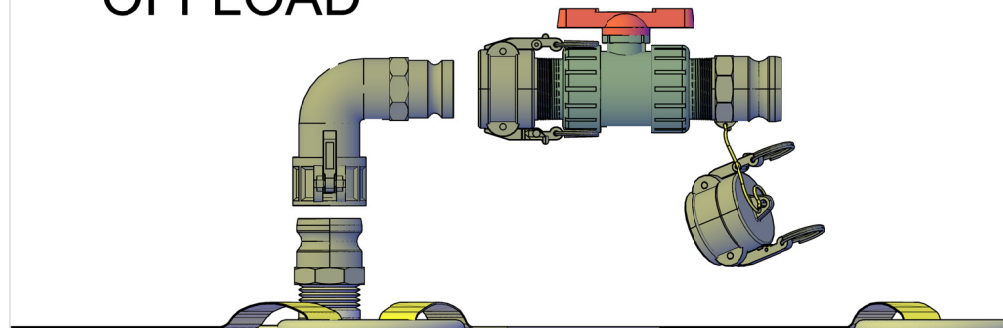

**FITTINGS
DETAIL**



**PROJECT: Fitting Arrangement
RECTANGULAR SHAPED TANK FOR
MTVR or LVSr Vehicle
"NAVFAC"**

CRT-1500

DRAWN: F.Y. DRWG #:1120-25

SCALE: N.T.S

DATE: 12/02/2020

REVISED:

**CANFLEX USA INC. PO BOX 1014 , 412 30th St , Anacortes,WA,98221,USA
Tel:(206)282-8233 ; Web: www.canflexinc.com**