



# canflex (USA), Inc.

## "Beach Sealing Boom"

### Features

- Available in 50ft / 15m and 65ft / 20m sections .
- Reflective strips on the splash flaps allow for good visibility.
- ASTM end connectors with toggle pin and sacrificial zinc anodes.
- Top inflatable chamber is equipped with one (1 PSI) relief valve and one Monsun air fill valve.
- Each of the two bottom ballast chambers are equipped with one (2 PSI) relief valve and one Monsun water filling valve.
- 2" interconnecting hose assembly with valve adapters (to fill/ offload the fluid in series of up to 4 x 65ft / 20m sections at a time).
- Carry / storage bag.
- Low maintenance and easily cleaned.
- Optional reinforced double layered base for added resistance against abrasive or jagged surfaces.
- Marine grade shipping / storage plywood box (Optional).



The water ballast containment booms are used to protect areas exposed to tidal flow. The beach boom has two interconnected bottom water chambers (ballast) with two fill/drain water valves and one top air chamber (buoyancy/ towing) with one fill/drain air valve. All chambers have automatic relief valves which protect the unit from overpressure.

The Beach Sealing Oil Boom is manufactured with high strength Urethane coated fabrics and its ends are reinforced to avoid tearing. Each section has two aluminum end quick connectors with stainless steel bolts and pins.

These units are collapsible and can be folded for easy storage and transportation.

### Applications include, but not limited to:

- Shoreline protection in shallow waters.
- Inter-tidal waters.
- Calm rivers.



MODEL	LENGTH	HEIGHT	FREEBOARD	DRAFT	DRY WEIGHT
	<i>m</i>	<i>mm</i>	<i>mm</i>	<i>mm</i>	<i>Kg/m</i>
	ft	inch	inch	inch	lbs/ft
BB-15M	15.2	660	330	330	5.0
	50.0	26.0	13.0	13.0	3.35
BB-20M	20.0	660	330	330	5.0
	65.0	26.0	13.0	13.0	3.35

MATERIAL CONSTRUCTION SPECIFICATIONS					
Urethane COATED TYPE	WEIGHT <i>g/m<sup>2</sup></i> <i>oz/yd<sup>2</sup></i>	FABRIC TYPE	FABRIC PROPERTIES	TENSILE STRENGTH <i>Kg/5cm</i> <i>lbf/in</i>	PUNCTURE RESISTANCE <i>Kg</i> <i>lb</i>
Oil & Water Resistant	1,200 35.3	Polyester	10,000 Cycles High abrasion resistance	700 / 600 780 / 670	190 420

Color- Orange

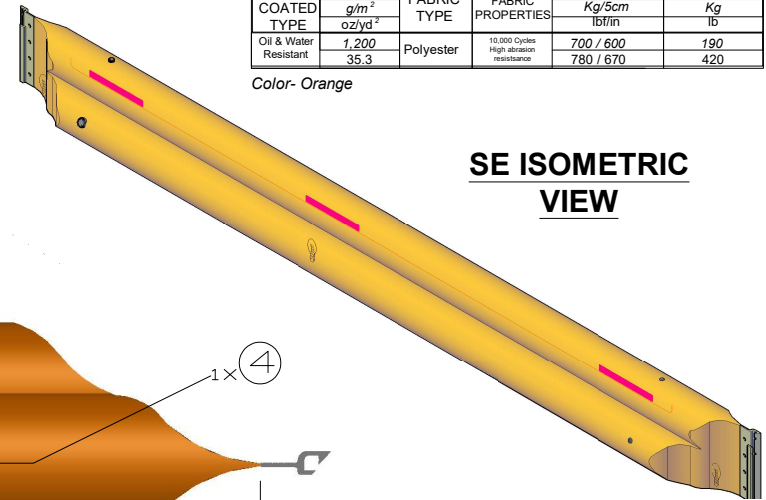

**SE ISOMETRIC VIEW**

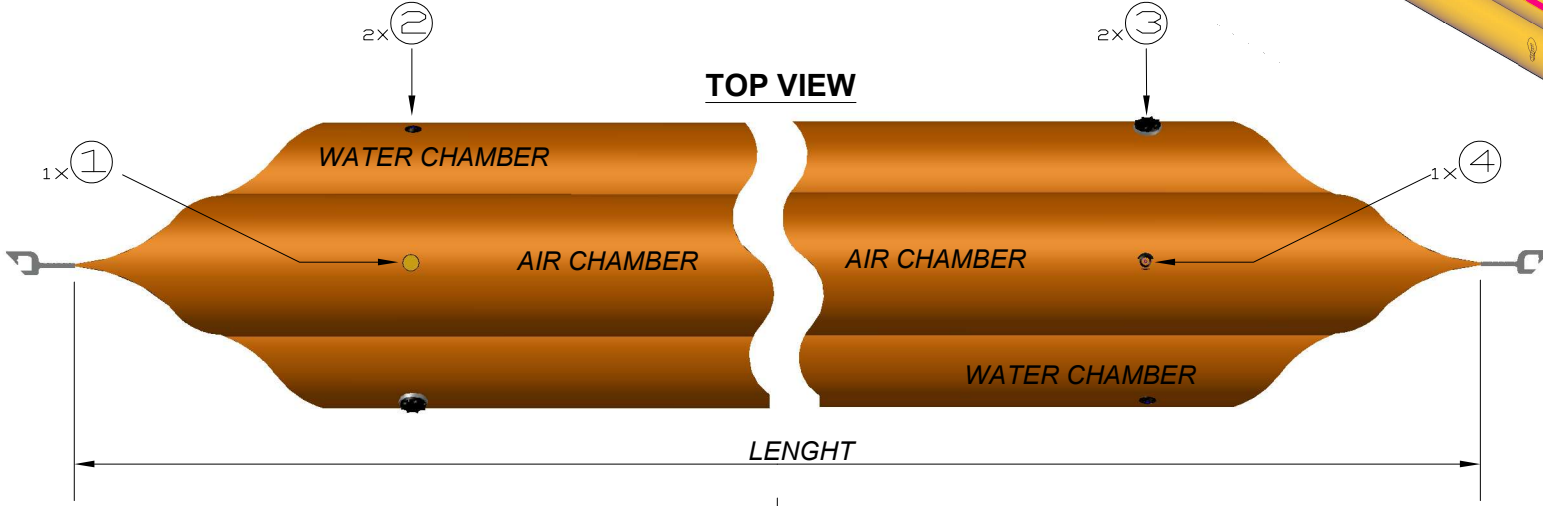

**TOP VIEW**

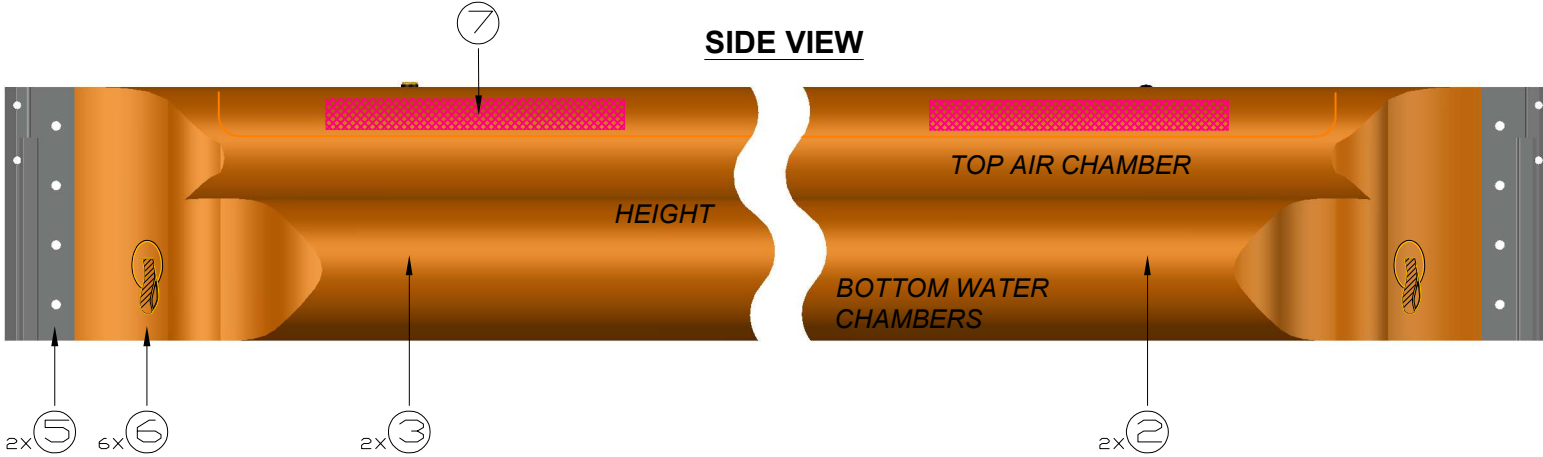

**SIDE VIEW**

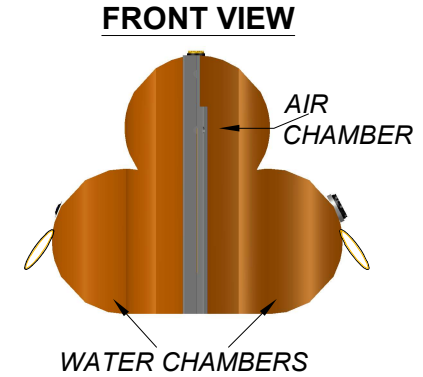

**FRONT VIEW**

ITEM NO.	QTY. REQD.	DESCRIPTION OF ITEM PER SECTION	PART #
1	1	1/2" AIR FILL/ OFFLOAD "MONSUN" VALVE	MSV1
2	2	FLUID RELIEF VALVE- 1 PSI	A10LP110PW
3	2	2" FLUID FILL/ OFFLOAD "MONSUN" VALVE	MXVII
4	1	AIR RELIEF VALVE- 1 PSI	A10LP110PW
5	2	ASTM CONNECTOR W/ BCKG PLATE ,TOGGLE PIN & ZINC ANODE	ASTM/24
6	6	500 WLL HEAVY DUTY HANDHOLD	HDL
7	6	2" LUMINOUS STRIP - ON BOTH SIDES	LMNS2



**PROJECT:**  
**CANFLEX BEACH SEALING OIL BOOM**

SCALE: N.T.S	MODEL: BB-15M & BB-20M	DRAWN BY: F.Y.
DATE: 10/14/2015		REVISED: 3/27/2022

**CANFLEX USA INC. PO BOX 1014 , 412 30th St , Anacortes,WA,98221,USA**  
**Tel:(206)282-8233 or (800)544-8356, Fax: (206)282-5933 or (800)635-8992; Web: www.canflexinc.com**